

12 Clintonville Road
Northford, CT 06472-1653
Phone: 203.484.7161

NDM-100 Dual Monitor Module

SPECIFICATIONS

Normal Operating Voltage:	15 to 32 VDC
Maximum Current Draw:	6.4 mA (LED on)
Average Operating Current:	750µA (LED flashing)
EOL Resistance:	47K Ohms
Maximum SLC wiring resistance:	40 Ohms
Maximum IDC wiring resistance:	1,500 Ohms
Maximum IDC Voltage:	11 Volts
Maximum IDC Current:	240µA
Temperature Range:	32°F to 120°F (0°C to 49°C)
Humidity:	10% to 93% Non-condensing
Dimensions:	4 1/2 in H × 4.275 in W × 1.4 in D (Mounts to a 4-inch square by 2 1/8-inch deep box.)
Accessories:	SMB500 Electrical Box

BEFORE INSTALLING

This information is included as a quick reference installation guide. Refer to the control panel installation manual for detailed system information. If the modules will be installed in an existing operational system, inform the operator and local authority that the system will be temporarily out of service. Disconnect power to the control panel before installing the modules.

NOTICE: This manual should be left with the owner/user of this equipment.

GENERAL DESCRIPTION

The Dual Monitor Module is intended for use in addressable, two wire systems. It provides two independent 2-wire initiating device circuits (IDC), at two separate, consecutive addresses. It is capable of monitoring normally open contact fire alarm and supervisory devices, or either normally open or normally closed security devices.

COMPATIBILITY REQUIREMENTS

To ensure proper operation, this module shall be connected to a compatible Notifier system control panel (list available from Notifier).

FIGURE 1. CONTROLS AND INDICATORS:

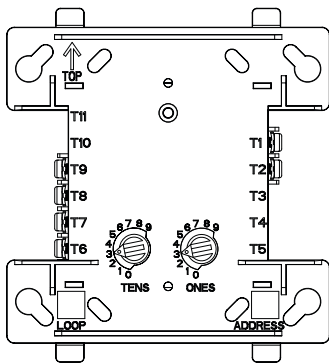

C0917-01

MOUNTING

Mounts directly to 4-inch square electrical boxes (see Figure 1). The box must have a minimum depth of 2 1/8 inches. Surface mounted electrical boxes (SMB500) are available from Notifier.

FIGURE 2. MODULE MOUNTING:

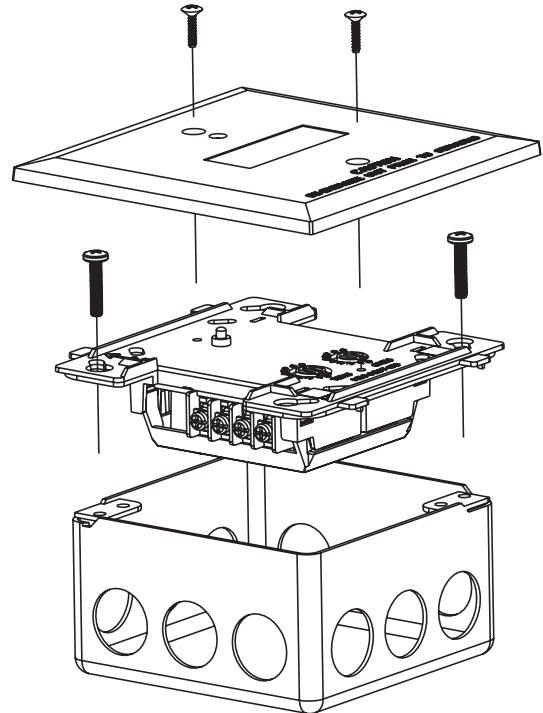

C1075-01

WIRING

NOTE: All wiring must conform to applicable local codes, ordinances, and regulations. This module is intended for power limited wiring only.

1. Install module wiring in accordance with the job drawings and appropriate wiring diagrams.
2. Set the address on the module per job drawings.

NOTE: Monitor module L (using terminals 6 and 7) responds at the address set on the code switches. Monitor module H (using terminals 8 and 9) will automatically respond at the next higher address. For example, if the code switches are set to 76, module L will respond at address 76 and module H will respond at address 77. Use caution to avoid duplicate addressing of modules on the system.

3. Secure module to electrical box (supplied by installer), as shown in Figure 2.

FIGURE 3. TYPICAL 2-WIRE INITIATING CIRCUIT CONFIGURATION, NFPA STYLE B:

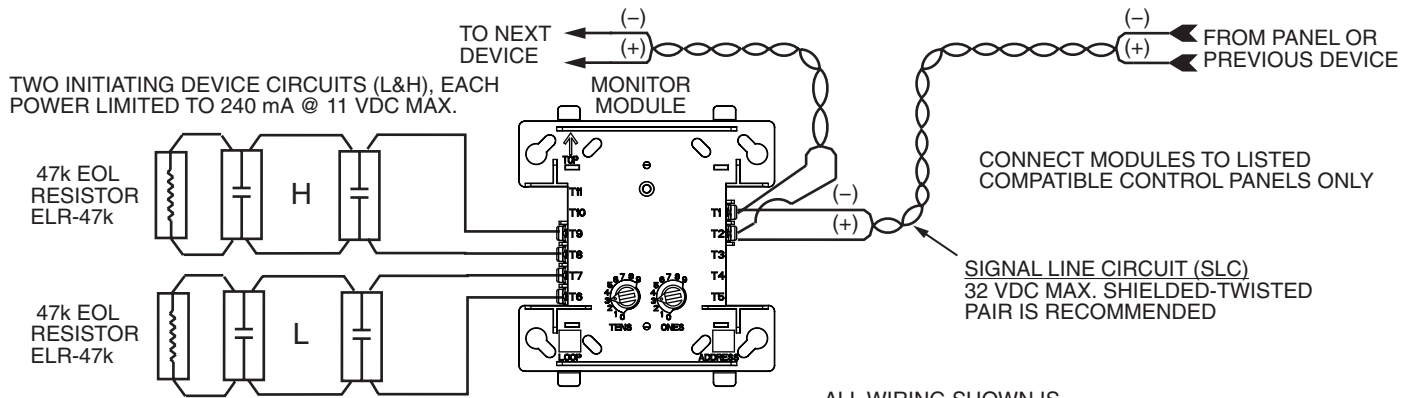

UL LISTED CONTACT CLOSURE DEVICES MAY BE USED. DO NOT MIX FIRE ALARM INITIATING, SUPERVISORY, OR SECURITY DEVICES ON THE SAME INITIATING DEVICE CIRCUIT.

INSTALL CONTACT CLOSURE DEVICES PER MANUFACTURER'S INSTALLATION INSTRUCTIONS.

ALL WIRING SHOWN IS SUPERVISED AND POWER LIMITED

MONITOR L (TERMINALS 6 & 7) RESPONDS AT ADDRESS SET ON CODE SWITCHES. MONITOR H (TERMINALS 8 & 9) RESPONDS AT NEXT HIGHER ADDRESS.

C1074-01