

STI HORN/STROBE DAMAGE STOPPERS®



STI-1210B



STI-1221E



STI-1217



STI-1225



PRODUCT OVERVIEW

These virtually indestructible covers (slotted for horn or speaker units and solid for strobe-only alarms) are designed to stop vandalism and accidental damage. Molded of clear, thick, UV-stabilized polycarbonate material, they are backed by a three year guarantee against breakage in normal use. Slots in the STI-1210, 1215, 1217 and 1219 allow the horn to be heard. The STI-1221, 1225, 1227 and 1229 are for strobes only. Many tough, clear spacers are available for larger strobe/horn units, retrofits, surface-mount and weather resistant applications. For the STI-1210/1221 series, spacer A has a four inch deep enclosed back box, spacer B has an enclosed back box molded with an integral double-gang outlet box. Spacer C has an open back for retrofit applications. Spacer D accommodates deeper units and applications with exposed conduit electrical connections. Spacer E has an open back frame for flush-mount applications. An appliance mounting plate comes with the STI-1219/1229. Unique Enviro Kits are available for extreme conditions where dampness or water is present.

KEY FEATURES

General Information

- Helps prevent accidental and intentional damage or vandalism.
- See chart for light and sound loss information.
- Easy access for service.
- Three year guarantee against breakage of polycarbonate in normal use.

Design

- Various back box and spacer depths are available to accommodate special applications.

Construction

- Covers are UV-stabilized.
- Typical working properties of polycarbonate are -40° to 250°F (-40° to 121°C).

Options

- Enviro Kit available for harsh conditions.
- See STI-1229HTR heated Type 4X enclosure for strobes in freezing conditions.

STI Horn/Strobe Damage Stoppers®

Dimensions and Technical Information

MODELS AVAILABLE

Horn/Strobe Damage Stopper

- STI-1210A** Cover and encl. back box, 4" deep, weather resistant
- STI-1210B** Cover and encl. back box, double-gang outlet box
- STI-1210C** Cover open back box, external mounting tabs
- STI-1210D** Cover and open back box, open conduit back box for surface mount applications and mounting around exposed conduit
- STI-1210E** Cover and open back box, flush mount

Strobe Damage Stopper

- STI-1221A** Cover and encl. back box, 4" deep, weatherproof, drain vent, Type 3R
- STI-1221A4X** Cover and encl. back box, 4" deep, weatherproof, Type 4X
- STI-1221A4X-WD** Cover and enclosed back box, 4" deep, weatherproof, Type 4X, for wash down areas
- STI-1221B** Cover and solid encl. back box, double-gang outlet box
- STI-1221C** Cover and open back box, external mounting tabs
- STI-1221D** Cover and open back box, conduit knockout
- STI-1221E** Cover and open back box, flush mount

Accessories

- KIT-84** Tamper resistant screws
- KIT-121** Enviro Kit for D and E models
- KIT-122** Enviro Kit for B and C models
- KIT-06297D** "D" spacer only
- KIT-06297E** "E" spacer only
- STI-1283** Backplate for "D" and "E" models
- STI-3003** Conduit Gasket
- KIT-19038** Bit for tamper resistant screws
- KIT-6297B20** 3/4" conduit hub for "B" and "C" back box (outdoor rated)

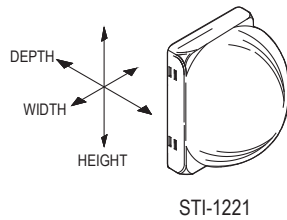
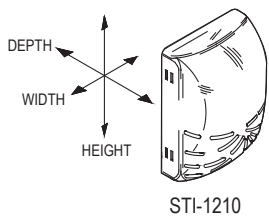

STI-1210 Series Horn/Strobe Covers				STI-1221 Series Strobe Covers		
Spacer	H	W	D	H	W	D
A	8.5 in. (216mm)	6.5 in. (165mm)	6.25 in. (159mm)	8.5 in. (216mm)	6.5 in. (165mm)	6.25 in. (159mm)
B	8.5 in. (216mm)	6.5 in. (165mm)	3.5 in. (89mm)	8.5 in. (216mm)	6.5 in. (165mm)	3.5 in. (89mm)
C	8.5 in. (216mm)	6.5 in. (165mm)	4.75 in. (120mm)	8.5 in. (216mm)	6.5 in. (165mm)	4.75 in. (120mm)
D	8.5 in. (216mm)	6.5 in. (165mm)	5.75 in. (146mm)	8.5 in. (216mm)	6.5 in. (165mm)	5.75 in. (146mm)
E	8.5 in. (216mm)	6.5 in. (165mm)	4 in. (102mm)	8.5 in. (216mm)	6.5 in. (165mm)	4 in. (102mm)

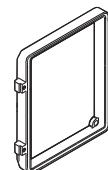
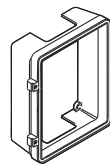
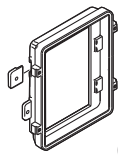
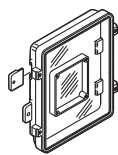
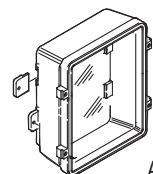

APPROVALS & WARRANTY

TESTING

- It has been tested and approved or listed by:
- Underwriter Laboratories and Canadian UL File S7025
 - cUL approval for UL 1638 only
 - Type 3R STI-1221A
 - Type 4X STI-1221A4X, STI-1221A4X-WD
 - CSFM needs local approval
 - UL Listed for fire voice speakers for STI-1210 series only
 - ADA Compliant

WARRANTY

Three year guarantee against breakage of polycarbonate in normal use.

Performance Review Manufacturer

STI-1210 SERIES	Light Loss %
ADT SECURITY (ADTG1-V Series), EST/EDWARDS(G1-V Series, G1-HV Series, G1-HOV Series, EG1-V Series, EG1-HV Series, EG1-HOV Series), HONEYWELL (XLSG1-V, XLSG1-HV, XLSG1-HOV Series), MIRCOM (MG1-V, MG1-HV, MG1-HOV Series), SIEMENS (G1-V Series), ZITON PTY LTD (ZG1-V Series)	40%
EST/EDWARDS (2440S, 202 Series), HONEYWELL (XLS202 Series), MIRCOM (MS Series), MIRTONE (MG1-V Series), SIEMENS (202 Series)	43%
AMSECO-(SL24W-153075 CLEAR, A, B, G or R, SL24C-3075110 A, B, G or R, CSL24W-A, B, G or R, CSL24C-A, B, G or R), MIRCOM (FS-240), POTTER ELECTRIC (AS-24-153075R, AS-24-153075W)SYSTEM SENSOR (SS24110ADA)	47%
SYSTEM SENSOR (P2, PC2, P4, PC4, SX, SC)	53%
STI-1221 SERIES	
AMSECO-(SL24W-153075 CLEAR, A, B, G or R, SL24C-3075110 A, B, G or R, CSL24W-A, B, G or R, CSL24C-A, B, G or R), MIRCOM (FS-240), POTTER ELECTRIC (AS-24-153075R, AS-24-153075W)	26%
DETECTION SYSTEMS (GES24 Series), GENTEX (GES24 Series), HARRINGTON SIGNAL (GES24 Series), NATIONAL TIME & SIGNAL (GES24 Series), SECUTRON (GES24 Series)	31%
ADT SECURITY (ADTG1-V Series), EST/EDWARDS (G1-V Series, G1-HV Series, G1-HOV Series, EG1-V Series, EG1-HV Series, EG1-HOV Series), HONEYWELL (XLSG1-V Series, XLSG1-HV Series, XLSG1-HOV Series), MIRCOM (MG1-V, MG1-HV, MG1-HOV Series), SIEMENS (G1-V Series), ZITON PTY LTD. (ZG1-V Series)	34%
AMSECO (SL24W-153075), SYSTEM SENSOR (SS24110ADA)	37%
EST/EDWARDS (2440S, 202 Series), HONEYWELL (XLS202 Series), MIRCOM (MS Series), MIRTONE (MG1-V Series), SIEMENS (202 Series)	45%
FARADAY LLC (2700)	57%
SYSTEM SENSOR (P2, PC2, P4, PC4, SX, SC)	61%

STI Generic Light Loss Values: STI-1210 Series 53%, STI-1221 Series 61%.

Use of horn/strobe cover on audible device decreases the sound output by 6dB(A).

SPACER

DESCRIPTION

- A Enclosed back box, 4" deep (includes neoprene gasket)
- A4X Enclosed back box, 4" deep Type 4X (includes silicone gasket)
- B Enclosed back box with double-gang outlet box
- C Open back box with external mounting tabs
- D Open back box with conduit knockout
- E Open back box for flush mount

STI Horn/Strobe Damage Stoppers®

Dimensions and Technical Information

MODELS AVAILABLE

Stopper Dome for Horn/Speaker/Strobe

- STI-1215 flush mount
- STI-1217 with open back box
- STI-1219 with encl. back box

Stopper Dome for Strobe only

- STI-1225 Flush mount
- STI-1227 Open back box
- STI-1229* Enclosed back box, Type 4X
- STI-1229-WD Enclosed back box, Type 4X, for wash down areas

Accessories

- STI-1212 Spacer kit
- STI-1222 Enclosed back box for Stopper Dome
- STI-1284 Single Gang Mounting Adapter for STI-1219 and STI-1229
- KIT-84 Tamper resistant screws
- KIT-86 Tamper resistant screws (6) for STI-1215 and STI-1225
- KIT-123 Enviro Kit includes three gaskets
- KIT-19038 Bit for tamper resistant screws

*Hazardous models available. See STI-1229.

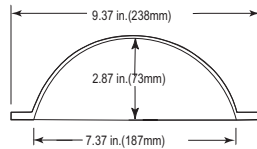

STI-1215 / STI-1225

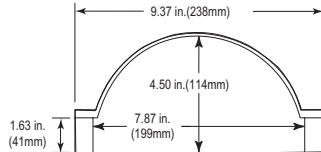

STI-1217 / STI-1227

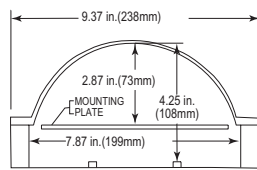

STI-1219 / STI-1229

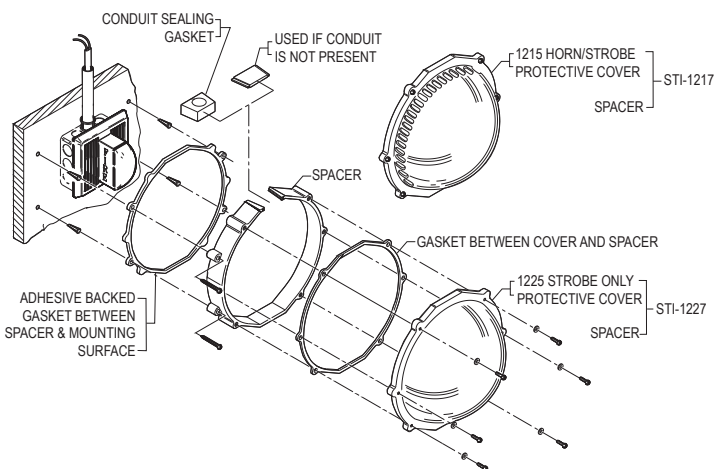

APPROVALS & WARRANTY

TESTING

It has been tested and approved or listed by:

- Underwriter Laboratories and Canadian UL File S7025
- cUL approval for UL 1638 only
- Type 4X STI-1229, STI-1229-WD
- CSFM needs local approval
- For hazardous applications in Canada, to meet cUL, your strobe must be ULC Listed
- ADA Compliant

WARRANTY

Three year guarantee against breakage of polycarbonate in normal use.

Performance Review Manufacturer

STI-1215/17/19 SERIES

ADT SECURITY (ADTG1-V Series), EST/EDWARDS (G1-V Series, G1-HV Series, G1-HOV Series, EG1-V Series, EG1-HV Series, EG1-HOV Series), HONEYWELL (XLSG1-V Series, XLSG1-HV Series, XLSG1-HOV Series), MIRCOM (MG1-V Series, MG1-HV Series, MG1-HOV Series), MIRTONE (MG1-V Series), SIEMENS (G1-V Series), ZITON PTY LTD (ZG1-V SERIES)

Light Loss %

20%

AMSECO (SL24W-153075), AMSECO-COLORED LENSES (SL24W-153075 A, B, G or R, SL24C-3075110 A, B, G or R, CSL24W-A, B, G or R, CSL24C-A, B, G or R), MIRCOM (FS-240), POTTER ELECTRIC (AS-24-153075R, AS-24-153075W)

22%

FARADAY (2700), SIEMENS (U-MCS Series)

23%

DETECTION SYSTEMS (GES24 Series, GES24-15/75), GENTEX (GES24 Series, GES24-15/75), HARRINGTON SIGNAL (GES24 Series, GES24-15/75), NATIONAL TIME & SIGNAL (GES24 Series, GES24-15/75), SECUTRON (GES24 Series, GES24-15/75)

27%

SYSTEM SENSOR (SS24110ADA)

26%

EST/EDWARDS (2440S Series, 202 Series), HONEYWELL (XLS202 Series), MIRCOM (MS Series), SIEMENS (202 Series)

33%

WHELOCK (RSS-24MCW)

34%

WHELOCK (RSS-24MCC)

36%

SYSTEM SENSOR (P2, PC2, P4, PC4, SX, SC)

39%

STI-1225/27/29 SERIES

SYSTEM SENSOR (P2, PC2, P4, PC4, SX, SC)

28%

WHELOCK (RSS-24MCW)

31%

ADT SECURITY (ADTG1-V Series), EST/EDWARDS (G1-V Series, G1-HV Series, G1-HOV Series, EG1-V Series, EG1-HV Series, EG1-HOV Series), HONEYWELL (XLSG1-V Series, XLSG1-HV Series, XLSG1-HOV Series), MIRCOM (MG1-V Series, MG1-HV Series, MG1-HOV Series), MIRTONE (MG1-V Series), SIEMENS (G1-V Series), ZITON PTY LTD. (ZG1-V SERIES)

32%

FARADAY (2700), SIEMENS (U-MCS Series)

33%

EST/EDWARDS (2440S Series, 202 Series), HONEYWELL (XLS202 Series), MIRCOM (MS Series), SIEMENS (202 Series)

34%

WHELOCK (RSS-24MCC)

35%

SYSTEM SENSOR (SS24110ADA)

36%

AMSECO (SL24W-153075), AMSECO-COLORED LENSES

(SL24W-153075 A, B, G or R, SL24C-3075110 A, B, G or R, CSL24W-A, B, G or R, CSL24C-A, B, G or R) SCM24W), DETECTION SYSTEMS (GES24 Series, GES24-15/75), GENTEX (GES24 Series, GES24-15/75), HARRINGTON SIGNAL (GES24 Series, GES24-15/75), HONEYWELL (XLSG1-HOV Series), MIRCOM (FS-240), NATIONAL TIME & SIGNAL (GES24 Series, GES24-15/75), POTTER ELECTRIC (AS-24-153075R, AS-24-153075W), SECUTRON (GES24 Series, GES24-15/75)

37%

Sound loss for STI-1215, 1217 and 1219

Horns: Amseco Audible Horn Sounders - 6.2 dBA

Speakers: Siemens Adapter Series (0.5, 1, or 2 watt taps only) - 4.1 dBA

STI Horn/Strobe Damage Stoppers®

Dimensions and Technical Information

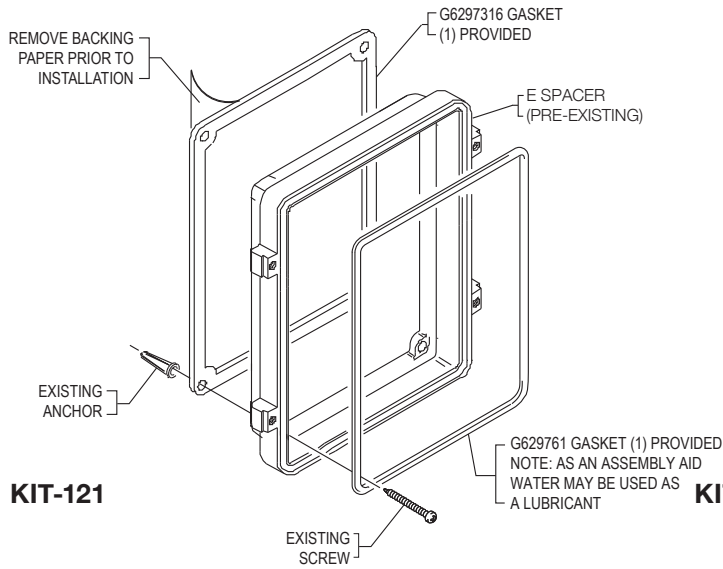

KIT-121

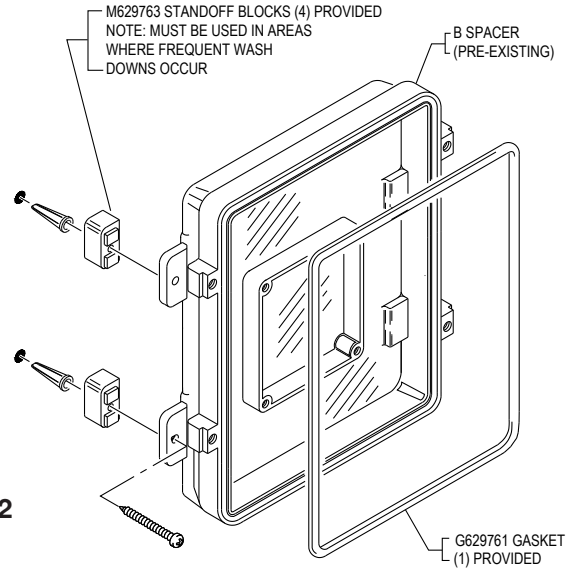

KIT-122

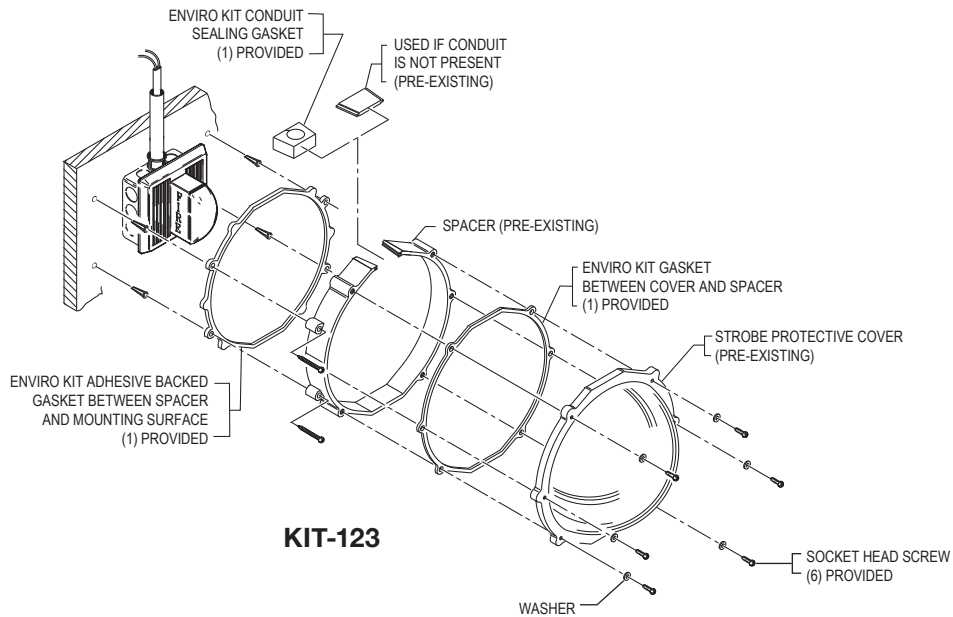

KIT-123



Safety Technology International

2306 Airport Road
Waterford, MI
48327, USA
info@sti-usa.com
www.sti-global.com
Tel: 248-673-9898

Taylor House
34 Sherwood Rd., Bromsgrove,
Worcs., B60 3DR, England

info@sti-emea.com
www.sti-global.com
Tel: +44 (0) 1527 520 999

Unit 7A Lockheed Avenue
Airport Business Park
Waterford X91 HWF2 Ireland